

RS-485 Communications Tester

~ EE 391 Preliminary Design Review ~

30 March 2007

Raymond Weber
Lance Spotted Elk

Table of Contents

Design Summary:	1
Design Objectives:	2
Functional Block Diagrams:	
Master Functional Block Diagram.....	3
Roving Tester.....	4
Data Source.....	5
Roving Tester Subfunctions.....	6
Schematics and Bills of Materials:	
Roving Tester.....	8
Data Source.....	10
Theories Of Operation:	
Roving Tester	12
Selectable High Impedance Voltage Divider.....	12
Voltage Stabilizer.....	13
MOSFET Controlled Power Switch.....	13
User Interface Switches.....	14
LCD.....	14
Systems in need of additional work.....	14
Data Source.....	15
Overvoltage Protection (Thermal Fused).....	15
High Impedance Voltage Divider.....	15
LED Warnings.....	15
Software Functionality :	
Roving Tester Routines.....	16
Data Source Routines.....	17

Design Summary:

Jr/Sr (EE391/EE492) design project to design a tester for RS485 Data Communication lines to detect errors such as crosses to AC as well as other line parameters. The tester will also have the ability to initiate and receive known communications between its components to test verify data integrity. The design will initially focus on using the DMX Protocol and later parallel firmware revisions will support alternate protocols such as LED Effects Protocol. The end usage of the device will be to test line integrity and wiring during the installation of LED Panels.

The Design will consist of two units that will interact with each other over the bus to verify the correct wiring of the bus and connectivity to the source unit of the bus with at correct speed, as well as checking the DC supply voltages provided to the led panels. The device must be configurable and adaptable to tolerate all current and future designs that may arise.

Osaka Chanel Building, Hong Kong



Design Objectives:

Roving tester:

- Test for overvoltage/AC on the all lines.
- Check Polarity of data lines.
- Check for both sides of twisted pair.
- Initiate Bi-Directional Communications of known test signal....
- Aggregate and display results for user
- Battery Powered

Data Source:

- Transmit known signal when prompted by roving tester, verify roving tester signal and send verification/aggregated RX packet quality....
- Also needs overvoltage/ac protection with basic line quality test procedures
- Outlet Powered

Both:

- RS-485 Electrical Signaling (Serial Multidrop LVDS protocol)
- 115k Baud Max
- 5-18V+ DC Supply voltage supplied
- DMX protocol compatible with ability for expansion to others
- 1 wire pair with common ground and power (4 wires total)

As time permits:

- Support for additional signaling protocols
- Enclosures (with the ability to withstand construction site usage)

Deliverables:

- Working prototype with pcb
- Documentation for the design and its usage
- Microcontroller source code

Functional Block Diagrams:
Master Functional Block Diagram

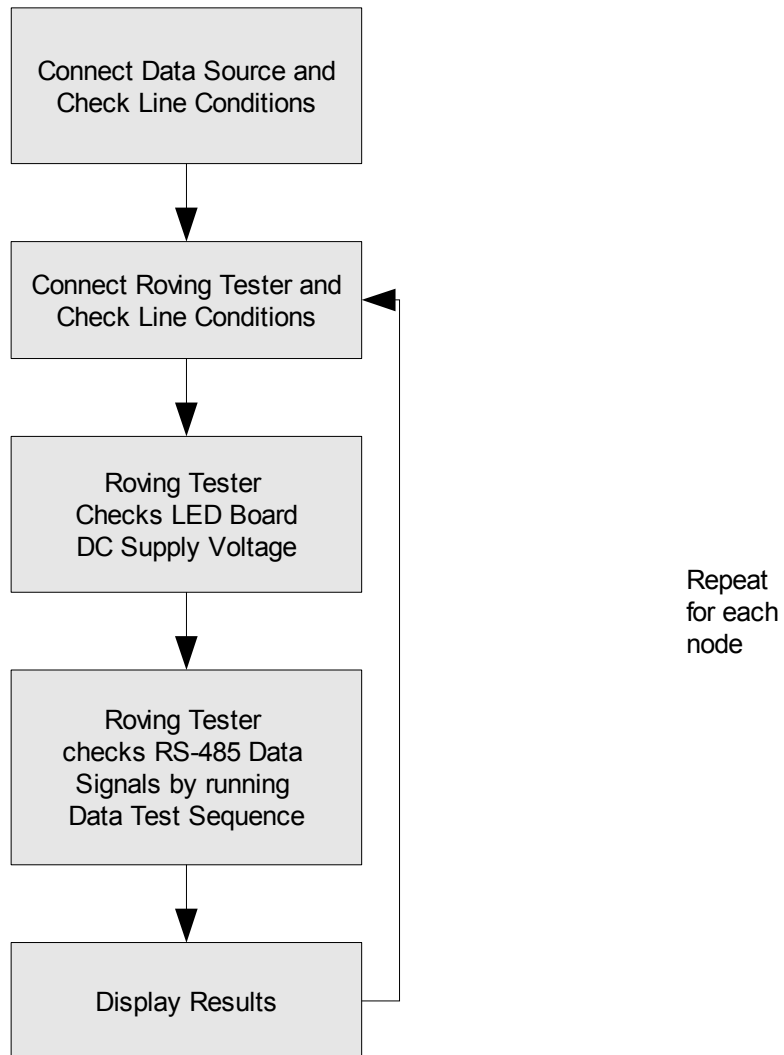

Roving Tester

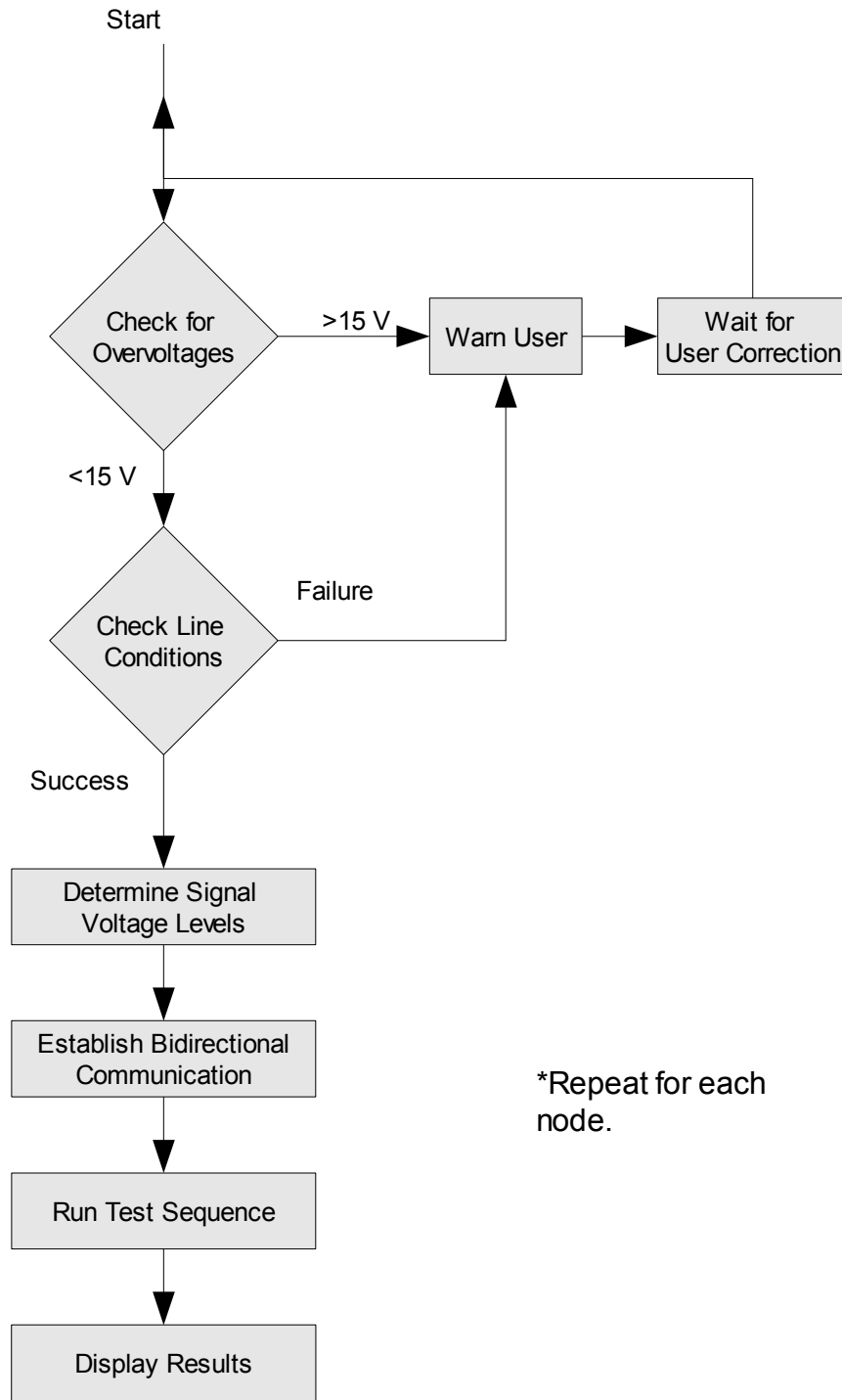

Data Source

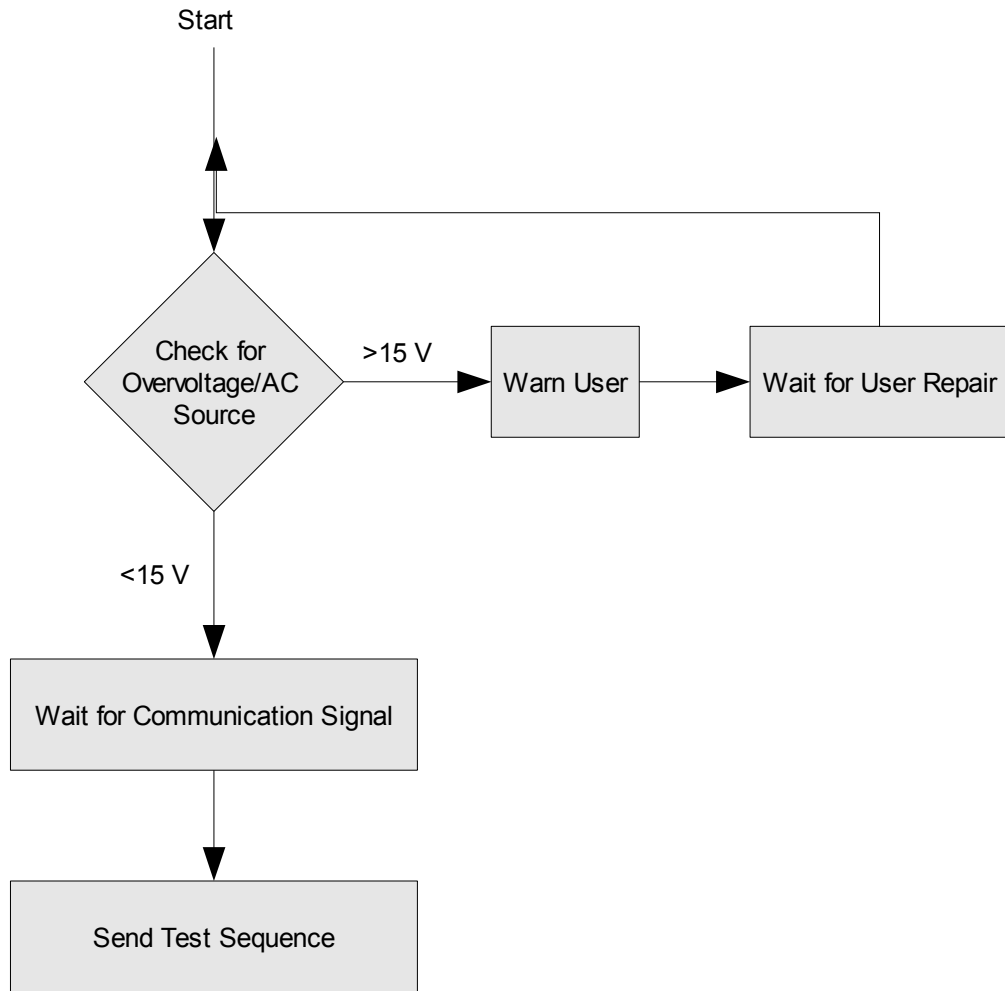

Roving Tester Subfunctions

Transmit Block Diagram

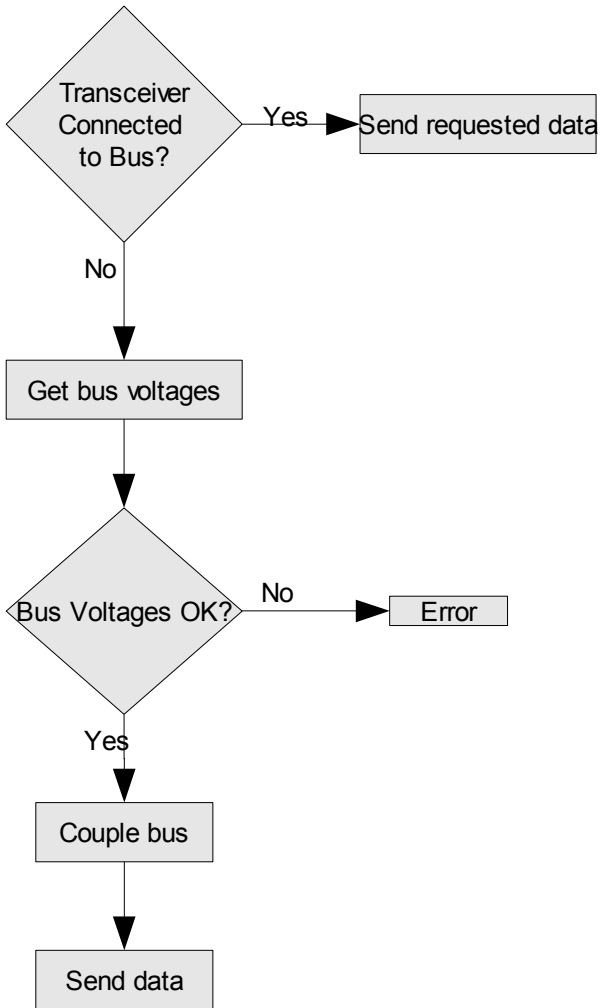

Test Sequence Functional Block Diagram

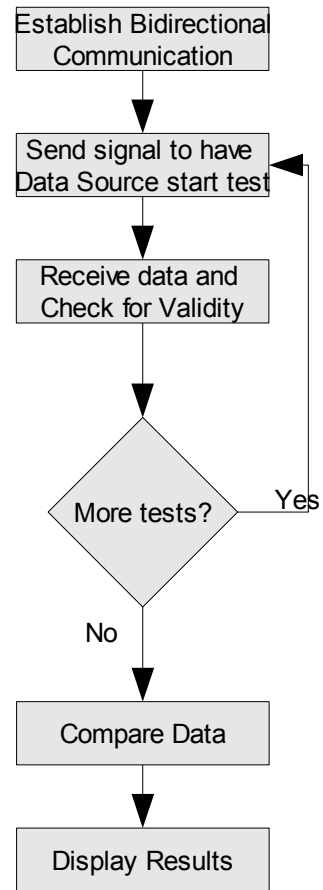

Check Voltage Level Block Diagram

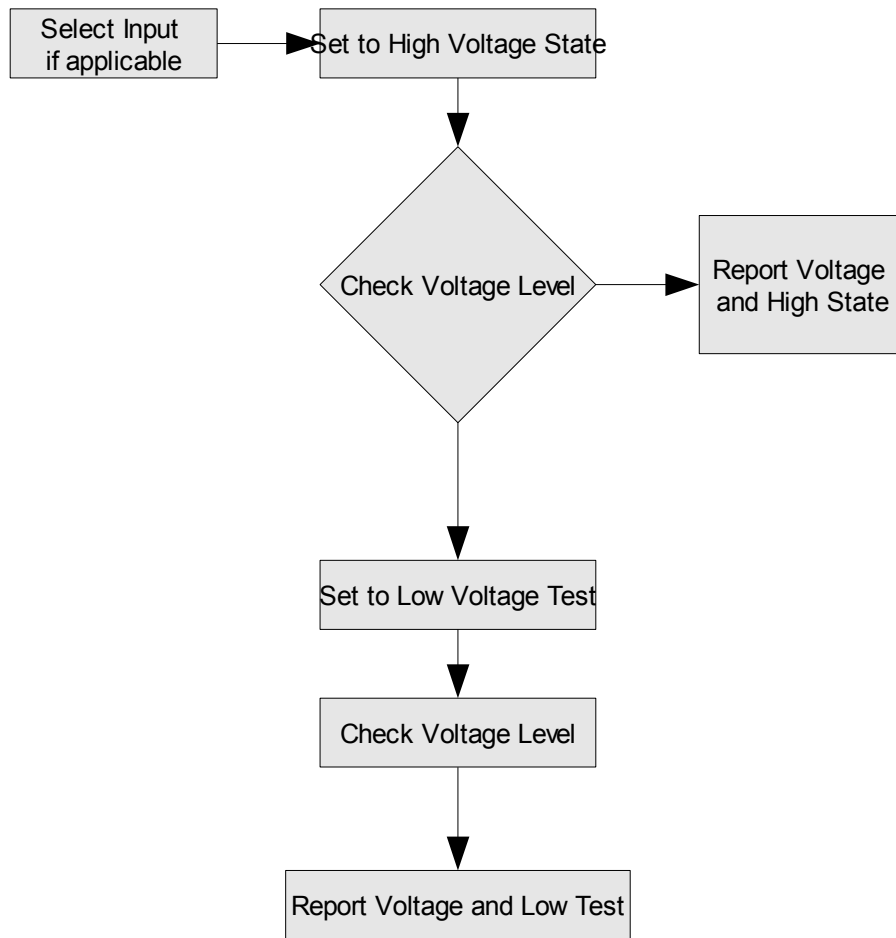

Schematics and Bills of Materials:

Roving Tester

Preliminary Bill of Materials

Roving Tester Side

Part Number:	Description:	Approx Price:	Quantity:
Max3080	Fault Protected Rs485 Transceiver	\$3.45	1
	Psoc uP		1
LCM-S01604DSR	16x4 LCD, Parallel interface	\$22.02	1
LM7805	5V Voltage Regulator	\$0.72	1
2N7000	N Channel Mosfet	\$0.26	3
G6L-1P-DC5	5V Relays	\$1.75	3
	Assorted 1/4W Resistors	\$0.08	
1N5333	5V Zener Diode	\$0.20	3
	Pushbutton Switch with keycaps		7
T350A334K035AT	.33uF capacitor (for regulator)	\$0.48	1
TAP104K050SCS	.1uF capacitor (for regulator)	\$0.52	1
	Large Resistors values for dividers, 1% or lower	\$0.10	9
OP275	Dual Op-Amp, high precision/speed	\$2.75	3
LM741	LM741 Op-Amp	\$0.40	1
2N4124BU	NPN BJT (for relay current)	\$0.11	1
44764-0601	6 Position Connector (through hole)	\$3.67	1
	120 ohm termination resistor		1

Data Source

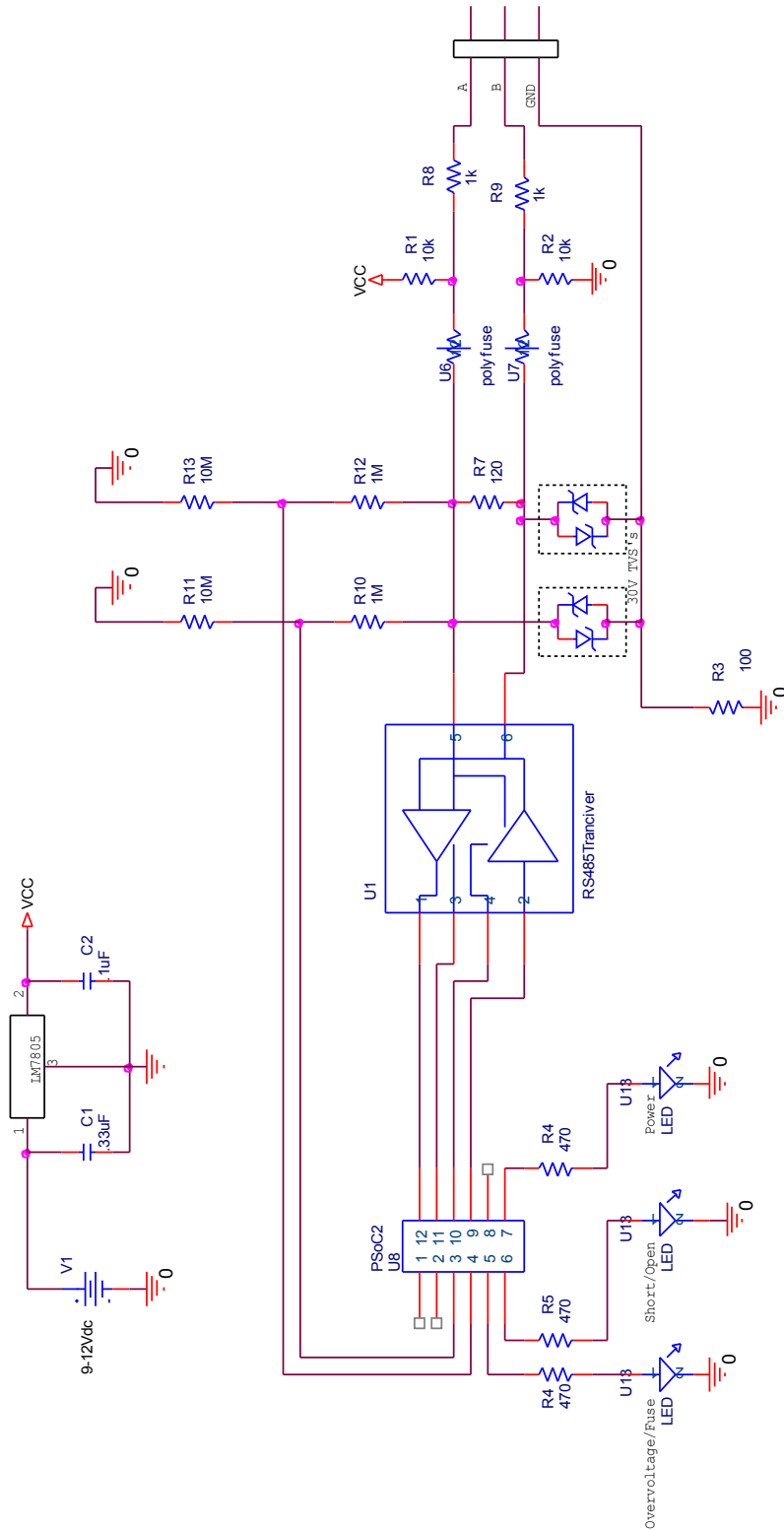

Title		RS485 Data Source	
Size	A	Document Number	na/
Rev	1.1	Date:	Thursday, March 29, 2007
		Sheet	1 of 1

Preliminary Bill of Materials

Data Source Side

<i>Part Number:</i>	<i>Description:</i>	<i>Approx Price:</i>	<i>Quantity:</i>
LO1785CN8	Fault Protected Rs485 Transceiver, 60V		1
	Psoc uP		1
LM7805	5V Voltage Regulator	\$0.72	1
T350A334K035AT	.33uF capacitor (for regulator)	\$0.48	1
TAP104K050SCS	.1uF capacitor (for regulator)	\$0.52	1
1N5333	5V Zener Diode	\$0.20	3
	Large Resistors values for dividers, 1% or lower	\$0.10	9
OP275	Dual Op-Amp, high precision/speed	\$2.75	3
LM741	LM741 Op-Amp	\$0.40	1
	Assorted 1/4W Resistors	\$0.08	
44764-0601	6 Position Connector (through hole)	\$3.67	1
	120 ohm termination resistor		1

Theories Of Operation:

Roving Tester

Selectable High Impedance Voltage Divider

This element allows for the selection of different voltage divider ratios to detect voltage levels. Initially it should be held in a testing state for high voltages and only later moved to the lower ranges if deemed safe to do so despite the zener as a second layer of protection to insure that voltages greater than 5V and less than 0 be sent to the uP. High value resistors are used to insure to limit the effect on the circuit and additional current drain with high tolerances to insure accuracy of the measurements

This works by having the MOSFET act as a switch between the resistors. If the bjt is powered by the uP, current is allowed to pass which allows for the resistors to act in parallel reducing their effective resistance. While unpowered no current (effectively) is allowed to pass and only one resistor to act in the divider.

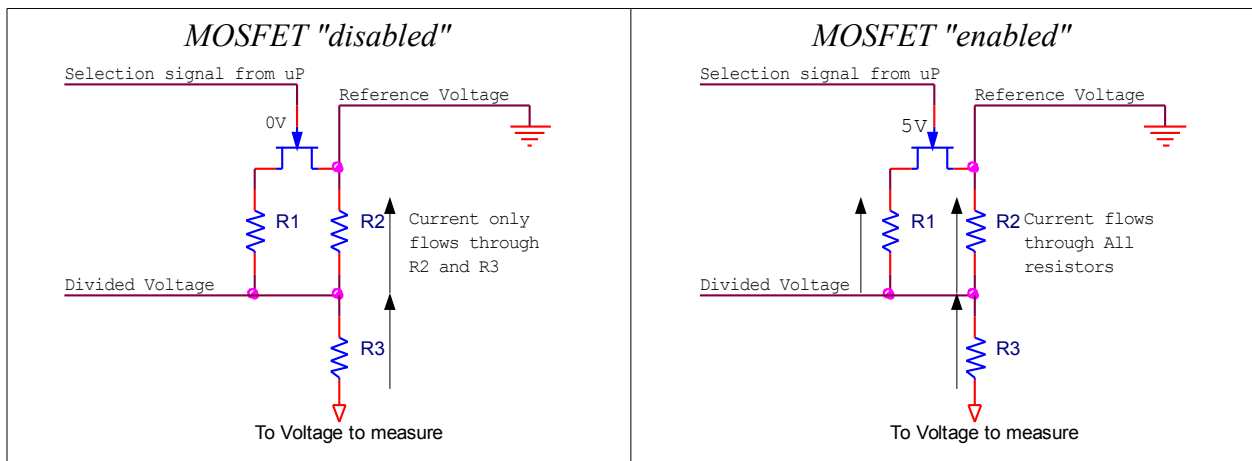

Voltage Stabilizer

A relatively high accuracy of the VCC supplied to the microprocessor is very desirable within the design as VCC provides the reference for the ADC Conversions. Using 14 bit ADC's within the microcontroller, small errors in reference could cause reductions in accuracy. A LM7805 is used for this as it has 2% voltage accuracy, and it is inexpensive and fairly easy to obtain, as well as providing ample current. It is able to achieve 5V with up to a 35V DC Source (Maximum Rating).

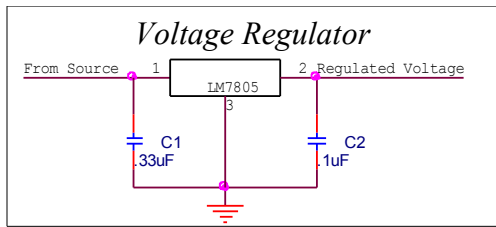

MOSFET Controlled Power Switch

A "soft" power switch is designed for use in the circuit as it will allow for better power saving features to be implemented and has virtually no current draw upon the battery while off.

This works by having a momentary switch bypass the MOSFET for a period of time allowing for the uP to initialize. Upon initialization of the uP, it will assert a signal to the mosfet allowing for a current path independent of the switch. When this has occurred, the switch can be depressed and the circuit will remain powered. A DPST switch should be used that will allow for a separate signal to be sent to the uP as well. This signal can be used to detect when the switch is depressed again and have the uP stop powering the MOSFET turning off the device. This can also be operated on a watchdog timer to turn of the device after a set number of minutes of inactivity to save battery power.

The disadvantage of this particular design is that it takes an additional two uP pins. As this is a non essential part, it may be eliminated if pins become limited.

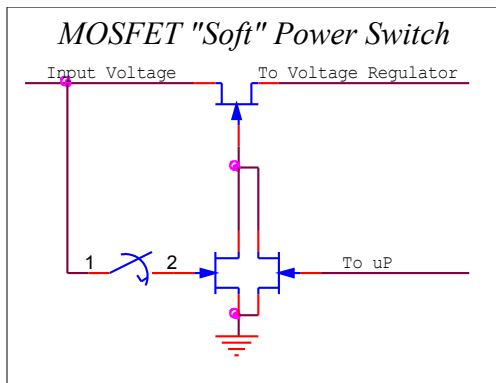

User Interface Switches

The user interface will be controlled by use of switches with directions. This can be implemented by using momentary switches with resistors between them and read using a ADC. The voltage present will correspond to a unique switch and can be acted upon. This has advantages over use of a parallel read touchpad by using only 1 input on the microcontroller, but losses in that it must be connected to one of the limited number of ADCs¹.

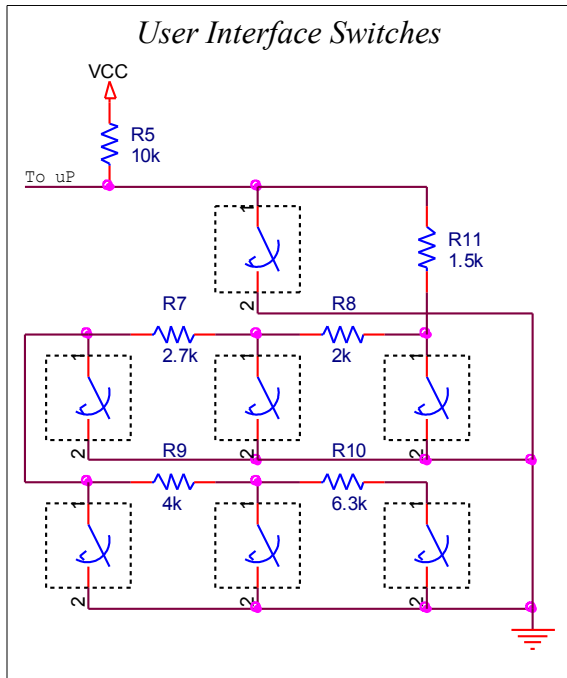

LCD

For this project a 16 char, 4 line display is planned for. This will allow for the space to display detailed test results to the user and simplify user interfaces reducing the time required to analyze the results. As UI design progresses this may be swapped for a 3 line to reduce costs if possible without compromising usability.

Systems in need of additional work

The major problem may still be present is in detection of AC on the Signal ground line. As the ground in the voltmeter is initially floating, it hasn't yet been determined if the floating voltage is going to be out of detection range for the Tester if its decoupled from the testers ground. Attaching directly to the ground before detection could cause irrational results and should be avoided. Galvanically coupling is a possibly still being explored but cost and complexity of the design rise dramatically, and still yields similar problems with components so far found (ADC on the coupled side will fluctuate causing the same problems).

¹ Technique from: *Freescale App Note AN1775, Expanding Digital Input with an A/D Converter*

Data Source

Overvoltage Protection (Thermal Fused)

The data source utilizes a RS-485 transceiver with higher voltage tolerances (60V as opposed to 15V) which allowed for a simpler voltage protection method to be implemented, however it may be counterbalanced with a longer reset time.

The overvoltage protection to the circuit is implemented by use of a trans-orbs connected with respect to ground to the RS-485 Data Bus. When the trans-orbs voltage level is exceed (at approximately 30V), it allows a higher current to pass limited only by a 47Ohm resistor. This heats a thermal fuse causing it to trip and protect the transceiver from the effects of the high voltages. This is wired as shown in the datasheet for the transceiver with additional current limiting resistors.

Additional circuitry and software will be implemented to detect the tripping of the fuse and its subsequent reset, as described more accuracy in the software implementation section.

This design reduces the complexity of the design and eliminates the need for relays and constant polling as this line should be in a constant receive mode. As a downfall, the recovery time is as of yet unknown, and will likely depend on ambient temperatures.

High Impedance Voltage Divider

The Data source implements a simplified version of the voltage divider from the Roving tester to check voltages on the bus. It is a much simplified version, mainly to insure the voltages on the buses are approximately correct and error if otherwise. This can be accomplished using a simple divider circuit with the op-amp series on the outputs.

LED Warnings

Due to that the data source isn't running tests and displaying complex outputs, their is little need for an expensive LCD display and instead LED's will be lit to display minimal information as to the health of the bus. LED's are present for On, Overvoltage/Fuse_En, and Open/Short line conditions.

Software Functionality :

Roving Tester Routines

High Range Voltage Test, RS-485 Line:

A Method to initially test the voltages of the line on the two RS-485 wires with the range select on high setting. Method should read multiple times to check for AC Waveforms as well as voltages that could damage the transceiver. When completed should set condition flags for an "AC_Detect", "Ok_To_Transmit", as well as analog readout of voltage detected.

Low Range Voltage Test, RS-485 Line:

A method called after the high voltage test to test for voltages with low range selected. Should also read multiple times to verify dc voltages only, and should modify AC flag and analog readout with more accurate measurements.

Voltage Test, PWR Line:

Method to check the voltage on the power line supplied with the RS-485 tester. Test should first be run in high voltage range and move to low voltage if within its range. Test should be run multiple time to verify DC signal. After test completed should compare value to user selected option and tolerances. Method should set flags for AC, OK, as well as actual voltage detected on the line.

Open Bus:

Method most likely called by Transmission method prior to first transmit. This method should verify that all the data bus is safe to couple to the transceiver and assert the line to close the relays. May also connect ground and PWR lines into the circuit and delay for transient to die out.

Transmit Signal:

Method that will activate the transceiver and send data as requested by other methods using a compatible TTL signal to the RS-485 specs.

Receive Signal:

Method activated after initial handshaking with data source to receive data from the data source and check it against expected signals.

Setup Menu:

A group of methods that will allow for the modification of parameters such as expected DC Voltages, and tolerances, as well as possibly data protocol, existence of PWR and bus speed. These options will be saved in Static Ram allowing for them to remain after power to the unit is lost.

Note: Software functionality is very likely to change as functionality of the PSoC is further explored as well as inevitable hardware revisions prior to the firmwares implementation.

Data Source Routines

Test LVDS Voltages

Method to read the voltages from the LVDS Bus and set flags/physical indicators if tripped. Will check multiple samples for the existence of AC on the line

Fuse Indicators

Method that will activate upon tripping of a thermal fuse in an overvoltage case. Upon removal of the overvoltage signal, this method will send a signal through the rs-485 lines to determine when the fuses have reset and turn of the indicator.

Wait

Method that will wait while listening to the lvds bus for a request to initiate bi-directional communications. This request may contain configuration options for the test that will need to be parsed and applied. Ideally this might be a low power mode with interrupt, if recovery time permits.

Receive

Method to receive and interpret requests from the bus.

Transmit

Method to transmit data to the RS-485 bus

Run Test Sequence

Method that will send pre-arranged signals to the transmit routine to run data quality tests